

CX 15

All Terrain 4x4 scissor lift platform

NEW



ATN

www.atnplatforms.com

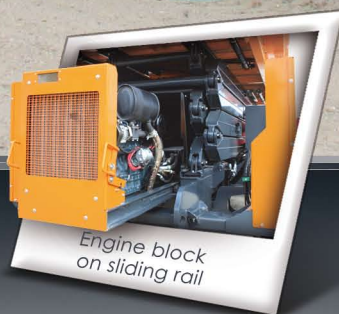

Engine block on sliding rail



7m30 platform with dual extension deck

CX 15

FTATN0008-01UK

ADVANTAGES

- Dual deck extension.
- Hydraulic extension deployment (optional).
- Easy maintenance (on-board diagnostic screen system).
- Intuitive proportional controls.
- Automatic levelling.
- Permanent 4x4.
- Designed for intensive use.

	CX15
Working height	15,00 m
Platform height	13,00 m
Max lift capacity	700 Kg
Lift capacity on extension	200 Kg
A Overall length	4,86 m
B Overall width	2,30 m
C Height with barrier in position	2,99 m
D Length with platform extensions	7,30 m
E Platform width	2,22 m
F Front and rear extension	2 x 1,25 m
G Height with barrier stowed	2,23 m
H Wheelbase	2,00 m
Ground clearance centre	0,36 m
Turning radius - inside	2,45 m
Turning radius - outside	5,60 m
Rough terrain special tyres	33 x 12 x 20

Raising / lower speed	40 / 40 s
Movement speed in stowed position	7 Km / h
Movement speed in up position	1 Km / h
Maximum tilt value	3 °
Gradeability	45 %

Diesel engine KUBOTA V2203 48 CV	36 KW
Fuel tank capacity	100 L
Hydraulic tank capacity	100 L
Total weight	7200 Kg

STANDARD FEATURES

- 4 Driving wheels.
- 2 Steered wheels.
- Stabilisers.
- On-board diagnostic system with colour LCD screen.
- Removable control unit.
- Load limiter.
- Tilt alarm.
- Time counter.
- Non-slip aluminium platform floor.
- Oscillating axle.

OPTIONS

- Hydraulic extension deployment.
- 220V AC power to platform.
- Air line to platform.
- Special paint colour(s).



This product complies with European regulations in force (EN 280).
Due to our constant improvement policy,
ATN reserves the right to many any modifications
without any prior notice.

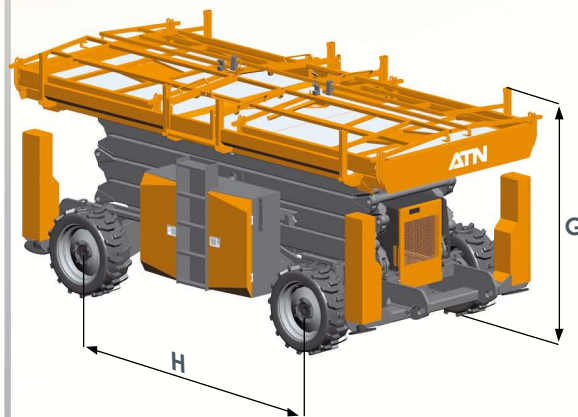
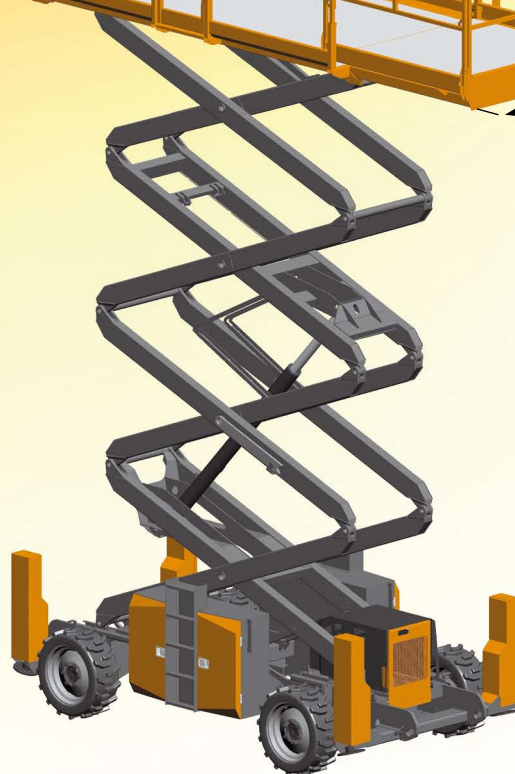
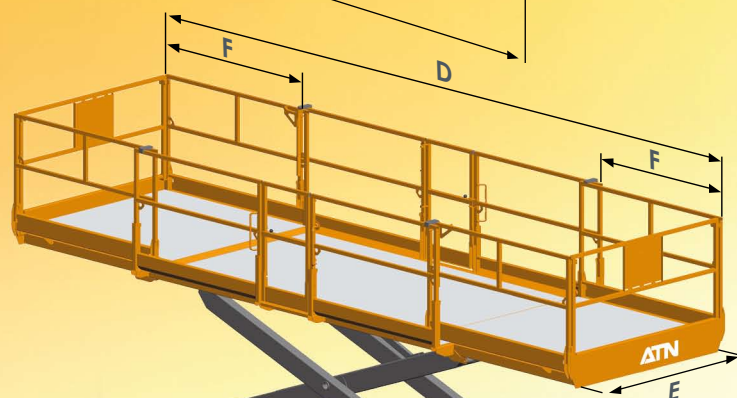
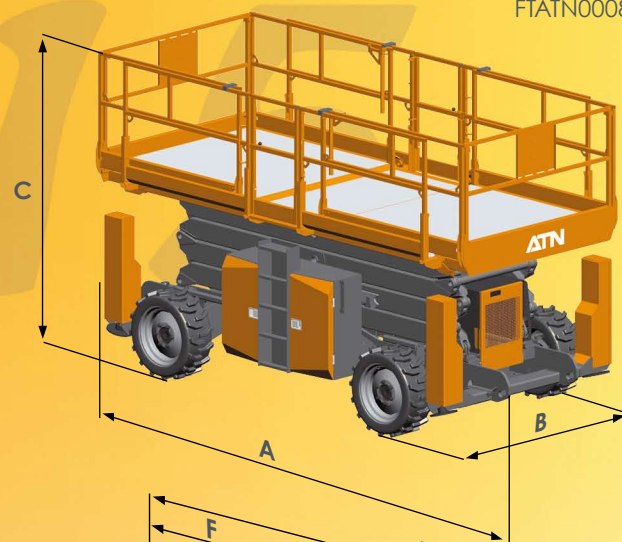

www.atnplatforms.com

6, impasse ZI de Suriray n°2 - 47400 Tonneins - FRANCE

Tél. : + 33 553 761 235 - Fax : + 33 553 880 107

e-mail : contact@atnplatforms.com