



**B 200 H**  
**B 200 H iLink®**

**MÁXIMA EFICIENCIA PARA LA LIMPIEZA URBANA**  
**MAXIMUM EFFICIENCY FOR URBAN CLEANING**  
**KEHRFAHRZEUG FÜR DIE KOMMUNE UND DEN DIENSTLEISTER**  
**LA NOUVELLE SOLUTION POUR LE NETTOYAGE DES RUES**



**A.F.S**  
AUSA Fuel Saving



**B 200 H iLink®**

**B 200 H**  
**B 200 H iLink®**

**AUSA**

www.ausa.com

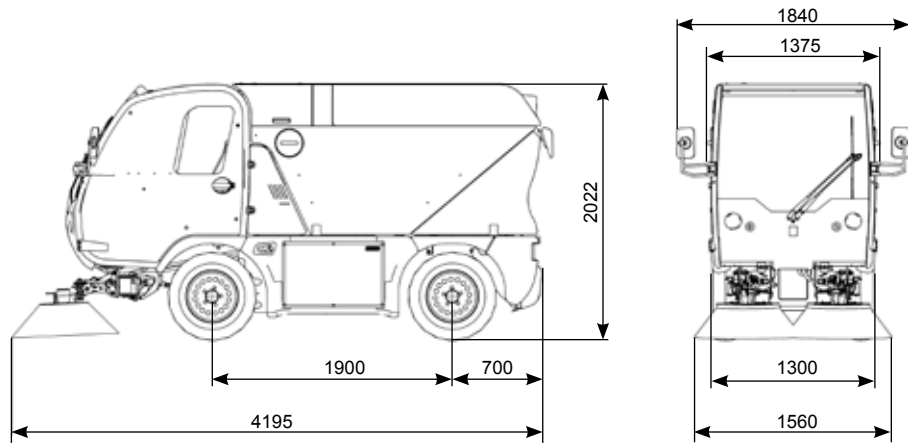

TECHNICAL SPECIFICATIONS		B 200 H / B 200 H iLink®		
		4x2x2	4x2x4	4x4x4 (FlowTrack®)
Waste Hopper	Capacity	2 m <sup>3</sup>		
	Dump Height	1580 mm		
	Discharge Type	Rear tilting		
	Material	Stainless Steel		
Water Tank	Capacity	300l		
	Material	HDPE Rotomoulding		
Turbine	Max Flow	9000 m <sup>3</sup> /h at 2250 rpm		
	Flow at optimal working speed	6000 m <sup>3</sup> /h at 1500 rpm		
	Turbine speed	Hydraulic control on turbine speed		
	Fan material	Steel - optionally Stainless Steel		
Suction Nozzle	Nozzle width	800 mm		
	Material	Stainless Steel		
Brush System	Type	2 independent brushes with control on width and height of brushing area		
	Wear adjustment	No need to adjust		
	Floor load	2 modes - Hydraulically controlled or mechanical floating system with weight compensation		
	Brush speed	Hydraulic control		
	Effective Sweeping width	2200 mm		
	Max Sweeping width	2500 mm		
	Brush diameter	850 mm		
	Type of brush	Mix Steel - Nailon with fast coupling system		
	Brush system material	Stainless Steel		
Maneuverability	External turning radius	3900 mm		2800 mm
	Internal turning radius	1400 mm		1050 mm
Engine	Make	VOLKSWAGEN		
	Type	2.0 TDI Euro 5		
	Emissions	Euro 5		
	Power	75 -102 (3000 rpm) kW-CV		
	N. Of Cylinders	4		
	Cooling system	Liquid with variable speed fan and auto cleaning system		
	Fuel	Diesel		
	Tank capacity	60 l		
Transmission	Type	2 speed hydrostatic Rexroth with wheel engines on rear axle		
	Max speed	40 km/h		
	Max working speed	25 km/h		
	Gradient negotiable	27% at full load (30% at 4500 kg)		37% at full load
Brakes	Service	2WD with front wheel steering		4 wheel steering Permanent 4wd and 4 wheel steering FlowTrack®
	Parking	Servo assisted brake, disk brake on front wheels and drum brakes on rear wheels Servo assisted brake. Drum brakes on rear wheels		
Steering	Type	Orbitrol hydraulic steering		
	Modes	Front		Front / Front + Rear
Suspension	Front	Hydraulic absorbers + Springs		
	Rear	Hydraulic absorbers, Springs and anti roll bar		
Weight	Unloaded weight	3050 kg		3100 kg
	Gross weight	5000 kg		
STANDARD EQUIPMENT		High visibility cabin with inspection windows for Nozzle and Brushes		
		Driver seat with mechanical suspension		
		Adjustable passenger seat		
		Steering wheel with regulation on height and depth		
		High capacity heater		
		Electronic control for the speed of the engine		
		Electronic control for the speed of the vehicle		
		Sweeping control system with proportional joysticks		
		Hopper filtration system with chains for leaf sweeping		
		Radio pre-installation		
		Approved lighting equipment with rotating beacon and 3 LED flashing lights on the back		
		AUSA fuel saving system (ASF)		
		3rd broom 850 m (overall width sweeping 2.850 mm)		
		Manual and extensible suction hose (4,5m)		
		Water high pressure equipment (10m hose; 150 bar)		
OPTIONAL EQUIPMENT		Sweeping water recycling system		
		Rear and Nozzle cameras		
		Driver seat with pneumatic suspension / Left hand drive (LHD)		
		Electrically adjustable rear mirrors with heater / LED Working lights on the top of cabin		
		Air conditioning / Radio CD / MP3 / Bluetooth		
		Broom working lights for night work		
		Snow-blade width 1500 mm with fast removable broom system		
		Water washer bar (spraying width 1500 mm) with water tank capacity 2000l (Mod. B 200 H iLink®System)		
		Three way hydraulic tipping body 1840x1300x420mm (Mod. B 200 H iLink®System)		
		Pole for high pressure water cleaning (Mod. B 200 H iLink®System)		
		Salt spreader capacity 1m <sup>3</sup> (Mod. B 200 H iLink®System)		
		LINK® System for the fast coupling / uncoupling of hopper, brushes and mouth (Mod. B 200 H iLink®System)		