



B 400 H

LA BARREDORA VIAL QUE FACILITA TU TRABAJO
THE URBAN SWEEPER THAT MAKES YOUR WORK EASIER
KEHRMASCHINE FÜR DEN KOMMUNALBEREICH WELCHE DAS ARBEITEN EINFACH MACHT!
LA BALAYEUSE QUI FACILITE VOTRE TRAVAIL



www.ausa.com

AUSA Center, S.L. ● Ctra. de Vic, Km 2.8 - P.O.B. 194. 08243 Manresa - BARCELONA (ESPAÑA) Tel.: +34 93 874 73 11 - E-mail: ausa@ausa.com

ISO 9001

ISO 14001



(Sede central AUSA-Manresa)

AUSA Madrid ● Pol. Ind. Coslada - C. Marconi 15-17. 28823 Coslada - MADRID (ESPAÑA) Tel.: +34 91 669 00 06 - E-mail: ausa.madrid@ausa.com

AUSA France ● Z. I. Saint Charles - Rue de Zürich, 66000 PERPIGNAN (FRANCE) Tel.: +33 (0) 4 68 54 38 97 - E-mail: ausa.france@ausa.com

AUSA Deutschland ● Heinrich - Welken Str. 5. 59069 HAMM (GERMANY) Tel.: +49 (0) 2384-9889905 - E-mail: ausa.deutschland@ausa.com

BEIJING Rep. Office ● Address Room 527. HengXiang Building, Tuanjehu Nanli, Chaoyang District. - BEIJING 100026 (CHINA)

Tel.: 86-10-8597 1983 - Fax: 86-10-8597 1993 - E-mail: ausa.china@ausa.com

AUSA UK ● Tel.: 07970639988 - E-mail: ausa.uk@ausa.com

AUSA Brasil ● Tel.: +55 51 33622111 - E-mail: ausa.brasil@ausa.com

AUSA México ● Calzada Vallejo, 725. 07750 Del. Gustavo A. Madero, México D.F. (MÉXICO) Tel.: +55 2166-9066 - E-mail: ausa.mexico@ausa.com



B 400 H



www.ausa.com

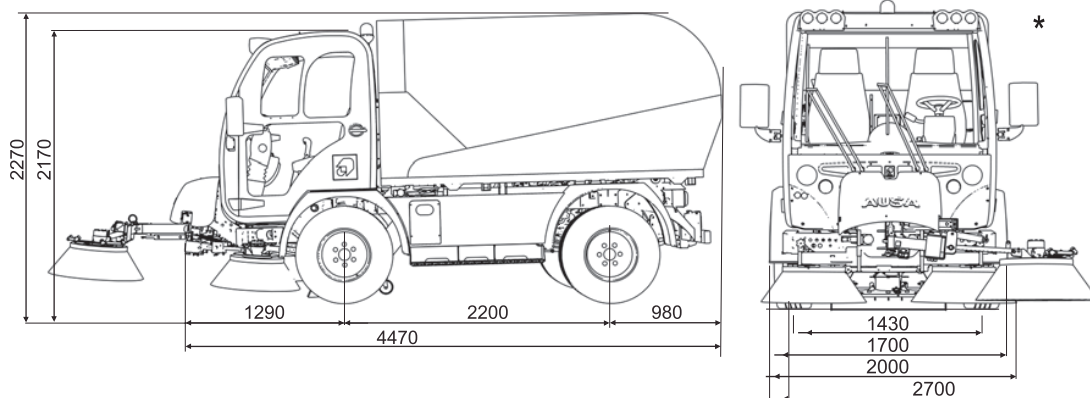

TECHNICAL SPECIFICATIONS

| | | B 400 H x2 / x4 |
|--------------------------------------|------------------------|--|
| Waste hopper ALUMINIUM | Capacity | 4 m ³ |
| Water tank INOX | Capacity | 500 l (INOX) |
| Sweeping system | Vacuum power | 13000 m ³ /h |
| | Brooms | 2 standard brooms of Ø850 mm / 3rd optional broom Ø850 mm |
| | Sweeping path width | 2000mm / 2700mm with 3rd optional broom |
| Vacuum nozzle | | Nozzle width 800 mm / Adjustable gate / Stainless steel |
| Engine | Make | VOLKSWAGEN |
| | Type | 2.01 TDI |
| | Emission regulations | EURO 5 |
| | Power (Kw - Cv) | 75-102 (3000 rpm) |
| | N. of cylinders | 4 |
| | Cooling | Liquid |
| | Fuel | Diesel |
| Tank capacity (l) | Fuel | 85 |
| Unloading system | Hopper discharge angle | 50° |
| | Backwards movement | 200 mm |
| | Hopper dump height | 1540 mm |
| Transmission | | 2 hydrostatic speeds + 2 mechanical speeds |
| | Maximum speed | Limited to 40 km/h or 25 km/h / Optional 62 Km/h available in certain countries |
| | Traction | 4x2 rear locking differential on demand |
| Gradient negotiable (with full load) | | 28% |
| Brakes | Service | Power-assisted hydraulic master cylinder, disc on front wheels and drum brake on rear wheels Optional ABS + EBD (Standard at 62 km/h) |
| | Parking | Negative parking brake, hydraulically released Hydraulically power-assisted steering |
| Steering | | Hydraulically power-assisted steering |
| Suspension | | Front suspension helicoidal spring & hydraulic damper Rear suspension parabolic leaf spring & Hydraulic damper |
| Weight (Kg) * | Unloaded weight | 4680 - 4740 (2490 front axle ; 2200 rear axle) |
| | Gross weight | 6400 (2650 front axle ; 3750 rear axle) |

STANDARD EQUIPMENT

- Front brooms (2) broom side-shift (+/- 200mm)
- Closed cabin with heating
- Doors with excellent visibility
- Electronic boost of rpm engine
- Monitor with 2 cameras: suction nozzle / backwards visibility
- Quick "LINK"® coupling / uncoupling fast system of optional interchangeable attachments for the sweeper
- Water coupling STORZ 2"
- Water couplings Barcelona 45 / 70
- Hose 5m
- Waste tank inspection window
- Seat with suspension
- Rotating beacon with telescopic support of 450mm length
- Electrically adjustable rear mirrors with heater
- Approved lightning system with electrical settings on head lamps
- Wheel wrench
- Wiring for transceiver set
- Radio-CD & MP3 + Bluetooth
- Front plate for attachments
- Right hand drive for better sweeping visibility

OPTIONAL EQUIPMENT

- Sweeping water recirculation system
- 3rd broom with long reaches (850mm)
- Auxiliary manual wander hose reaching up to 5 m / Ø160 mm
- High pressure water jet spray lance (150 bar / hose length 15m / possibility use of detergent)
- High pressure water jet spray lance with hose reel (150 bar / hose length 16m / possibility use of detergent)
- Standard support legs for taking-off the sweeping equipment
- Air conditioning
- Tacograph
- Seat with pneumatic suspension
- Towing hitch ball (50 mm) with electric socket (13 pins)
- Towing hitch "Rockinger" with electric socket (13 pins)
- Automatic lubrication system
- 62km/h with ABS + EBD and 2 mechanical speed
- ABS + EBD (on 40km/h version)
- 4x4 FULL GRIP® System and rear locking on demand

* Load or dimension data may change due to optional equipment